

	NAME	DATE	MICROTECH AUTOMOTIVE SYSTEMS	
DRAWN	THOMAS DECARIA	5/07/2021	TITLE	
CHECKED			CURVED 3.5" DASH LID	
ENG APPR			SIZE	CUSTOMER
MGR APPR			A4	MICROTECH AUTOMOTIVE
TOLERANCES $\pm 0.1$			REV	A
UNLESS OTHERWISE STATED DIMENSIONS ARE IN MILLIMETERS (mm)			FILE NAME: CURVED_LID_35	
SCALE: 1:1		WEIGHT:	SHEET 1 OF 2	

SOLID EDGE ACADEMIC COPY

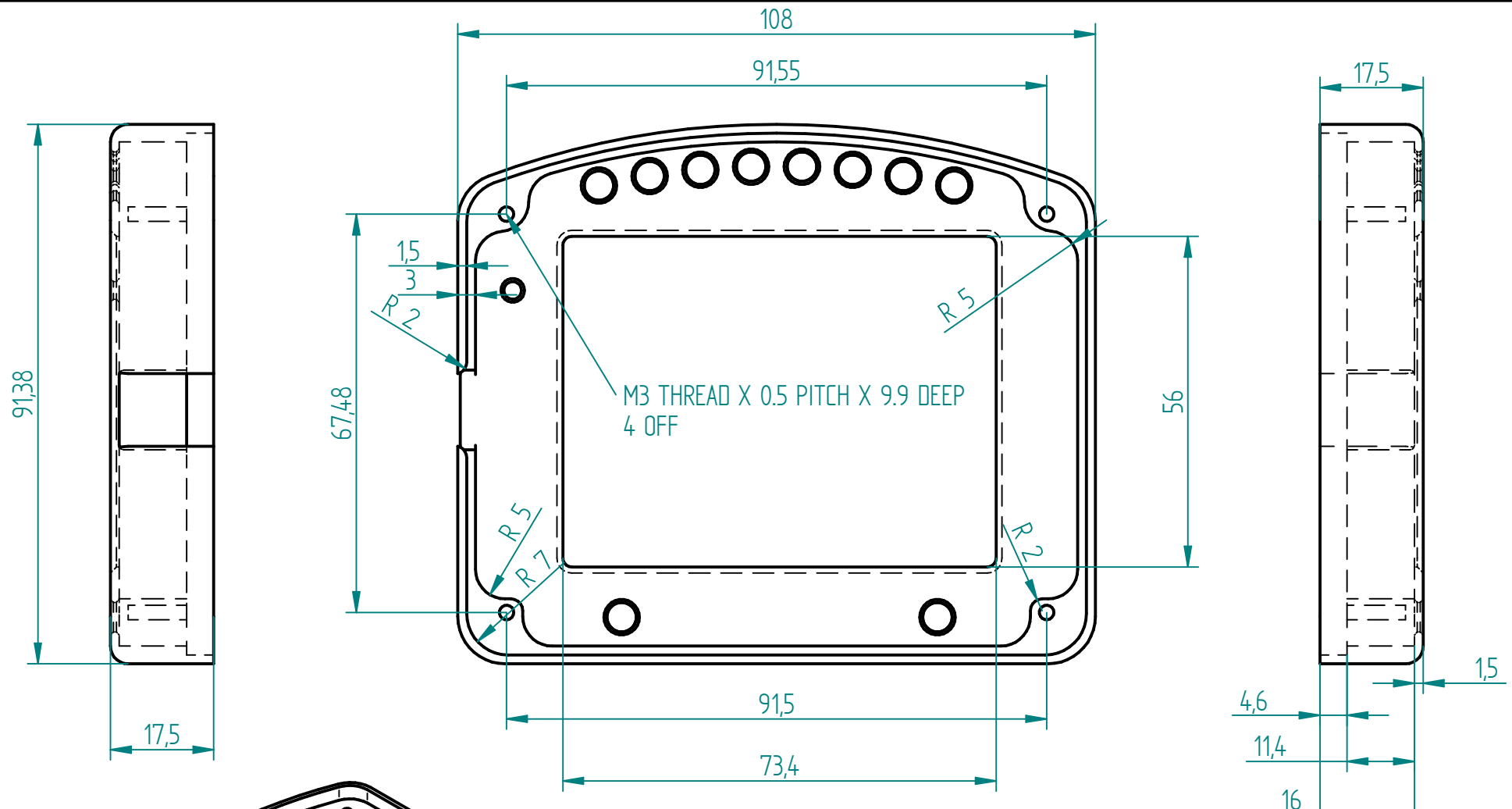

	NAME	DATE	MICROTECH AUTOMOTIVE SYSTEMS	
DRAWN	THOMAS DECARIA	5/07/2021	TITLE	
CHECKED			CURVED 3.5" DASH LID	
ENG APPR			SIZE	CUSTOMER
MGR APPR			A4	MICROTECH AUTOMOTIVE
TOLERANCES ± 0.1			REV	A
UNLESS OTHERWISE STATED DIMENSIONS ARE IN MILLIMETERS (mm)			FILE NAME: CURVED_LID_35	
SCALE: 1:1		WEIGHT:	SHEET 2 OF 2	

SOLID EDGE ACADEMIC COPY